

### CAT® ENGINE SPECIFICATIONS

#### V-12, 4-Stroke-Cycle

Bore	137 mm (5.4 in.)
Stroke	152 mm (6.0 in.)
Displacement	27 L (1649 cu. in.)
Aspiration	Turbocharged-Aftercooled
Governor and Protection	Woodward PROACT II
Combustion	Low Emission (Lean Burn)
Engine Weight, net dry (approx)	2141 kg (4720 lb)
Power Density	4.5 kg/kW (7.4 lb/bhp)
Power per Displacement	23.6 bhp/L
Engine Only Cooling System Capacity	54.9 L (14.5 gal)
Lube Oil System (refill)	170.3 L (45 gal)
Oil Change Interval	750 hours
Rotation (from flywheel end)	Counterclockwise
Flywheel and Flywheel Housing	SAE No. 0
Flywheel Teeth	136

### FEATURES

#### Engine Design

- Proven reliability and durability
- Ability to burn a wide spectrum of gaseous fuels
- Robust diesel strength design prolongs life and lowers owning and operating costs
- Broad operating speed range

#### Emissions

- Meets U.S. EPA Spark Ignited Stationary NSPS Emissions for 2007/8
- 2.0 g/bhp-hr NOx emission versions available
- Larger turbocharger and aftercooler provide lean air/fuel mixture, low emissions, and excellent fuel consumption

#### Lean Burn Engine Technology

Lean-burn engines operate with large amounts of excess air. The excess air absorbs heat during combustion reducing the combustion temperature and pressure, greatly reducing levels of NOx. Lean-burn design also provides longer component life and excellent fuel consumption.

#### Caterpillar Electronic Ignition System (EIS)

Detonation sensitive timing protects the engine against detonation damage. Higher voltage and longer spark duration mean easier starts, fewer misfires, and smoother operation. Diagnostic codes help pinpoint cylinder and component of interest. Spark plug maintenance codes identify spark plug condition.

#### Ease of Operation

- Deep sump oil pan has a larger capacity for normal 750-hour oil change intervals
- High-strength pan and rails for excellent mounting and stability
- Side covers on block allow for inspection of internal components

#### Full Range of Attachments

Large variety of factory-installed engine attachments reduces packaging time

#### Testing

Every engine is full-load tested to ensure proper engine performance.

#### Gas Engine Rating Pro

GERP is a PC-based program designed to provide site performance capabilities for Cat® natural gas engines for the gas compression industry. GERP provides engine data for your site's altitude, ambient temperature, fuel, engine coolant heat rejection, performance data, installation drawings, spec sheets, and pump curves.

#### Product Support Offered Through Global Cat Dealer Network

More than 2,200 dealer outlets

Cat factory-trained dealer technicians service every aspect of your petroleum engine

Cat parts and labor warranty

Preventive maintenance agreements available for repair-before-failure options

S•O•S<sup>SM</sup> program matches your oil and coolant samples against Caterpillar set standards to determine:

- Internal engine component condition
- Presence of unwanted fluids
- Presence of combustion by-products
- Site-specific oil change interval

#### Over 80 Years of Engine Manufacturing Experience

Over 60 years of natural gas engine production

Ownership of these manufacturing processes enables Caterpillar to produce high quality, dependable products.

- Cast engine blocks, heads, cylinder liners, and flywheel housings
- Machine critical components
- Assemble complete engine

#### Web Site

For all your petroleum power requirements, visit [www.catoilandgas.cat.com](http://www.catoilandgas.cat.com).

**STANDARD EQUIPMENT**

---

**Air Inlet System**

Air cleaner — single element with service indicator

**Control System**

Electronic governor

Air/fuel ratio control on 1.0 g/bhp-hr NOx engines

**Cooling System**

Thermostats and housing

Jacket water pump

Aftercooler water pump

Aftercooler core

**Exhaust System**

Watercooled exhaust manifolds

Dry exhaust elbow

**Flywheels & Flywheel Housings**

SAE No. 0 flywheel

SAE No. 1 flywheel housing

SAE standard rotation

**Fuel System**

Gas pressure regulator (1.5 to 5 psi gas supply required)

Natural gas carburetor

**Ignition System**

Cat Electronic Ignition System (EIS) with detonation sensitive timing

**Instrumentation**

Service meter

**Lube System**

Crankcase breather — top mounted

Oil cooler

Oil filter — RH

Oil pan — deep sump

Oil filler — RH in valve cover and RH dipstick

**Mounting System**

Engine supports

**Protection System**

Detonation sensitive timing control

Shutoff

**General**

Paint — Cat yellow

Crankshaft vibration damper and pulleys

Lifting eyes

**OPTIONAL EQUIPMENT**

---

**Air Inlet System**

Air cleaner — two-stage

Air inlet adapter

Precleaner

Air cleaner rain cap

**Charging System**

Battery chargers

Charging alternators

Ammeter gauge

Ammeter gauge and wiring

Control mounting

**Cooling System**

Radiators

Blower fan and fan drives for customer supplied radiators

Expansion tank

Heat exchangers

**Exhaust System**

Flexible fittings

Elbows

Flanges

Rain caps

Mufflers

**Fuel System**

Dual gas regulator

Carburetor kits

Fuel filter

**Ignition System**

CSA ignition

Ignition ground wiring harness

Power supply

**Instrumentation**

Alarm module

Gauges and instrument panels

**Mounting System**

Vibration isolators

**Power Take-Offs**

Auxiliary drive pulleys

Enclosed clutch and clutch support

Front stub shaft

Flywheel stub shaft

Pulley removal

**Protection System**

Gas valves

Status control box interconnect wiring harness

**Starting System**

Air starting motor — electric air start control

Air pressure regulator

Air silencer

Electric starting motors — single 24-volt

Starting aids

Battery sets

**General**

Special paint

**TECHNICAL DATA**
**G3412C LE Gas Petroleum Engine — 1800 rpm**

		<b>DM8627-01</b>
<b>Engine Power</b>		
@ 100% Load	bkW (bhp)	475 (637)
@ 75% Load	bkW (bhp)	356 (477)
<b>Engine Speed</b>		
Max Altitude @ Rated Torque and 38°C (100°F)	rpm	1800
Speed Turndown @ Max Altitude, Rated Torque, and 38°C (100°F)	m (ft)	609.6 (2000)
	%	21
<b>SCAC Temperature</b>		
	°C (°F)	54 (130)
<b>Emissions*</b>		
NOx	g/bkW-hr (g/bhp-hr)	2.68 (2)
CO	g/bkW-hr (g/bhp-hr)	2.64 (1.97)
CO <sub>2</sub>	g/bkW-hr (g/bhp-hr)	642 (479)
VOC**	g/bkW-hr (g/bhp-hr)	0.42 (0.32)
<b>Fuel Consumption***</b>		
@ 100% Load	MJ/bkW-hr (Btu/bhp-hr)	10.8 (7635)
@ 75% Load	MJ/bkW-hr (Btu/bhp-hr)	11.1 (7834)
<b>Heat Balance</b>		
Heat Rejection to Jacket Water		
@ 100% Load	bkW (Btu/min)	406.4 (23,133)
@ 75% Load	bkW (Btu/min)	340.3 (19,371)
Heat Rejection to Aftercooler		
@ 100% Load	bkW (Btu/min)	81.11 (4617)
@ 75% Load	bkW (Btu/min)	49.9 (2840)
Heat Rejection to Exhaust		
LHV to 25°C (77° F)		
@ 100% Load	bkW (Btu/min)	367 (20,906)
@ 75% Load	bkW (Btu/min)	272 (15,482)
<b>Exhaust System</b>		
Exhaust Gas Flow Rate		
@ 100% Load	m <sup>3</sup> /min (cfm)	97.13 (3430)
@ 75% Load	m <sup>3</sup> /min (cfm)	72.4 (2558)
Exhaust Stack Temperature		
@ 100% Load	°C (°F)	420 (788)
@ 75% Load	°C (°F)	407.2 (765)
<b>Intake System</b>		
Air Inlet Flow Rate		
@ 100% Load	m <sup>3</sup> /min (scfm)	38.45 (1358)
@ 75% Load	m <sup>3</sup> /min (scfm)	29.2 (1031)
<b>Gas Pressure</b>		
	kPag (psig)	10-34.47 (1.5-5)

\*at 100% load and speed, all values are listed as not to exceed

\*\*Volatile organic compounds as defined in U.S. EPA 40 CFR 60, subpart JJJJ

\*\*\*ISO 3046/1

### GAS PETROLEUM ENGINE

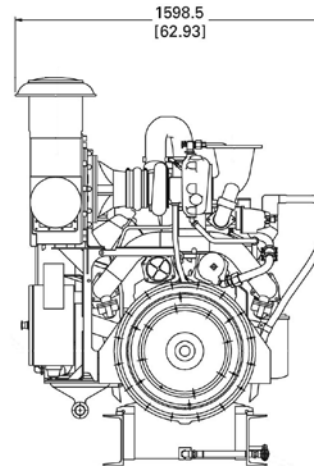
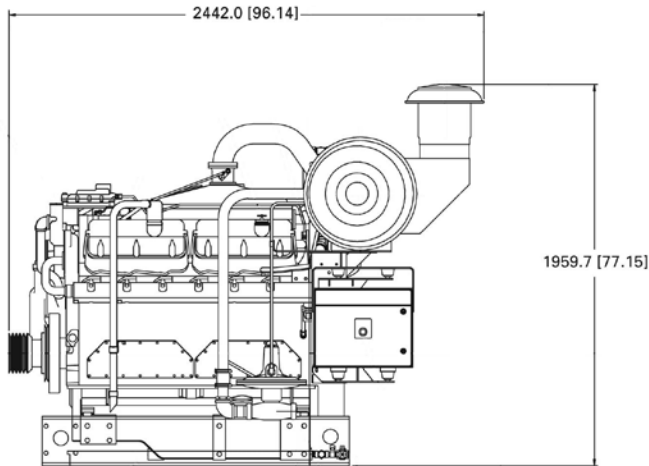

PACKAGE DIMENSIONS		
<b>Length</b>	mm (in.)	2442.0 (96.14)
<b>Width</b>	mm (in.)	1598.5 (62.93)
<b>Height</b>	mm (in.)	1959.7 (77.15)
<b>Shipping Weight</b>	kg (lb)	2141 (4720)

**Note:** General configuration not to be used for installation. See general dimension drawings for detail.

Dimensions are in mm (inches).

### RATING DEFINITIONS AND CONDITIONS

Engine performance is obtained in accordance with SAE J1995, ISO3046/1, BS5514/1, and DIN6271/1 standards.

**Conditions:** Power for gas engines is based on fuel having an LHV of 33.74 kJ/L (905 Btu/cu ft) at 101 kPa (29.91 in. Hg) and 15° C (59° F). Fuel rate is based on a cubic meter at 100 kPa (29.61 in. Hg) and 15.6° C (60.1° F). Air flow is based on a cubic foot at 100 kPa (29.61 in. Hg) and 25° C (77° F). Exhaust flow is based on a cubic foot at 100 kPa (29.61 in. Hg) and stack temperature.

Materials and specifications are subject to change without notice. The International System of Units (SI) is used in this publication. CAT, CATERPILLAR, their respective logos, S•O•S, "Caterpillar Yellow" and the "Power Edge" trade dress, as well as corporate and product identity used herein, are trademarks of Caterpillar and may not be used without permission.